



Liberty is here for you.
**Today. Tomorrow.
Together.**

For more information, please visit:
libertyinternational.com/au

 [Find a Crisis Management team member in Australia](#)

 [Office locations](#)

 [Connect with Liberty](#)

Small to medium sized suppliers of automotive components are most likely to be financially impacted

PRplus Automotive Component Recall insurance

Product recall cover

Understanding the financial impact of an automotive component recall

In the event of a safety or non-compliance issue with automotive components, businesses that manufacture, import, distribute or sell defective components, are responsible for taking recall action.

A recall event can be very expensive and small to medium sized suppliers of these automotive components are the most likely to be financially impacted.

The costs associated with a recall event:

- Repair, replacement and remanufacturing
- Dismantling and reinstallation
- Logistics and transportation to withdraw the product from the market
- Additional labour and staff to effect the recall of the affected product
- Product inspection
- Redistribution of restored products
- Public relations, including media releases and mass communications through a variety of channels to consumers, suppliers and distributors.

Examples of replacement, uninstallation and reinstallation costs:

Item	Replacement	Dismantling and reinstatement cost
Leaf springs	\$300 - \$500 (per unit)	\$200 - \$300 (per unit)
Drum brakes	\$100 - \$200 (per unit)	\$150 - \$200 (per unit)
Canopy wiring and electrical installation	\$100 - \$300 (per unit repair cost)	

At Liberty, we understand that this can be a significant financial stress on automotive parts suppliers.

We have built our PRplus Automotive Component Product Recall insurance to help protect businesses against the significant costs of a product recall event.

Components covered by the policy

Our PRplus Automotive Component Product Recall insurance covers vehicle parts including aftermarket spare parts and accessories. The exceptions to our risk appetite are tyres, airbags, seatbelt components and installation work.

Examples of vehicle parts that we commonly insure

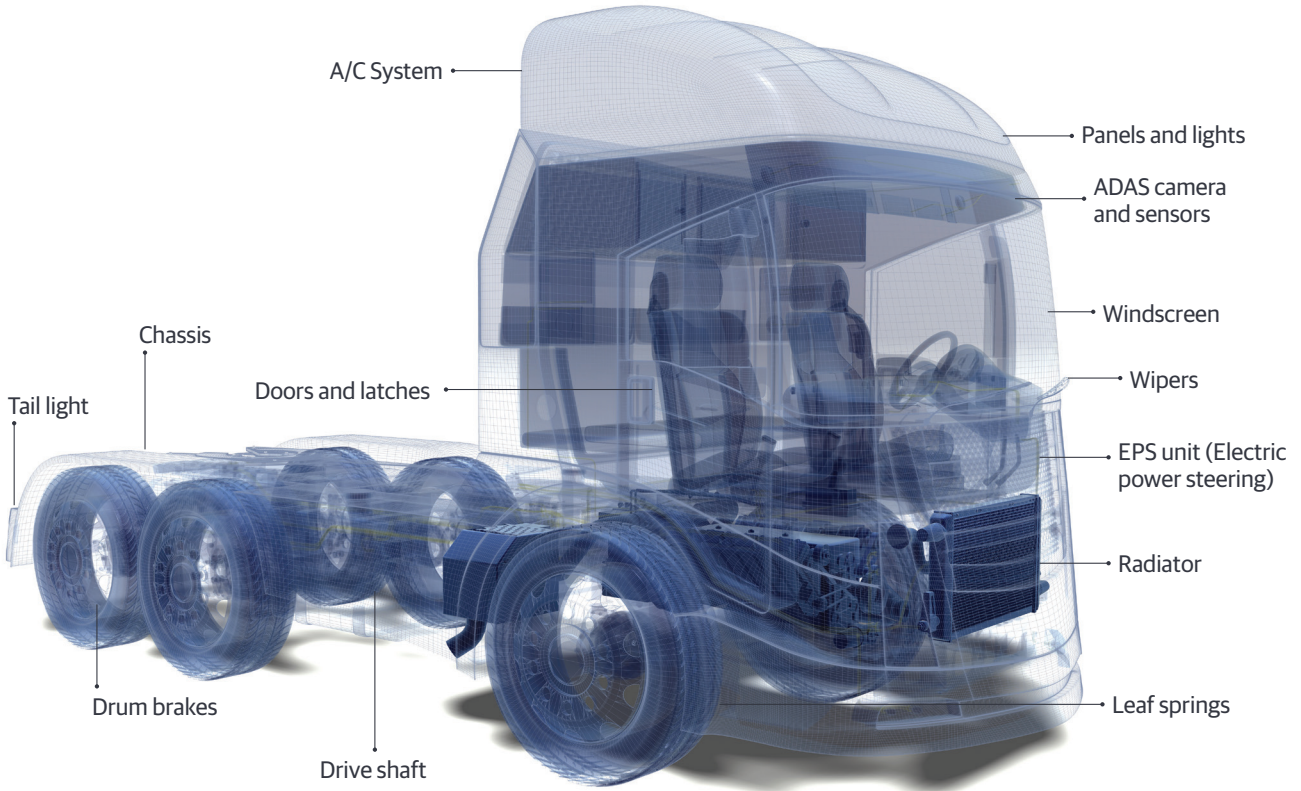

Vehicle accessories that we commonly insure

- Trailer (as shown)
- Jacks and stands
- Brake controller
- Tow bar and ball

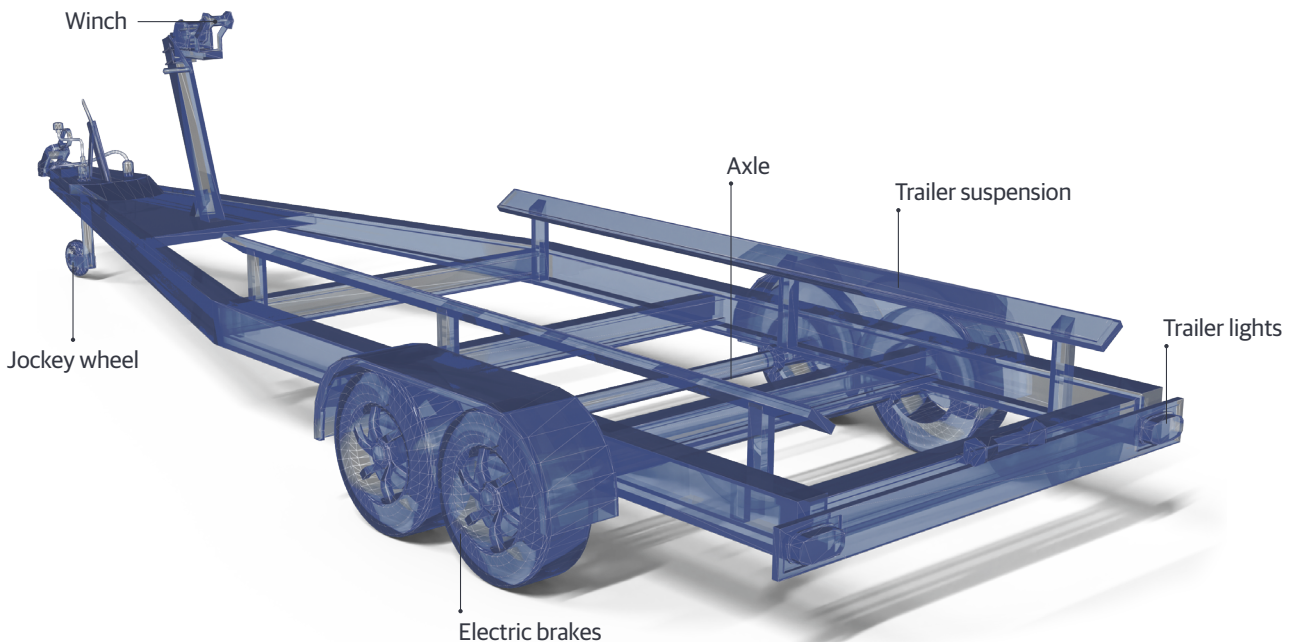



We offer
comprehensive
coverage with
unparalleled
expertise

Target clients:

- Manufacturers and suppliers of parts and systems
- Aftermarket industry

Our target clients are manufacturers and suppliers of parts and systems in the automotive supply chain. This includes the aftermarket industry, which plays a significant role in the automotive industry, especially after the exit of Australian car manufacturers several years ago.

Aftermarket parts can be categorised into spare parts & accessories

Spare parts: parts manufactured to replace original equipment parts as a result of normal wear and tear.

Accessories: parts made for comfort, performance, safety or customisation after the original sale of the vehicles.

Product Guarantee coverage for voluntary and compulsory recalls

All our policies come with Product Guarantee cover, which means that we have the ability to insure defective products which fail to perform their intended purpose. This is especially relevant for components that make up safety critical systems such as brakes, suspension and steering.

Our cover also extends to insuring non-safety related components where their functions are to increase the quality, comfort, functionality and performance in a vehicle.

Examples of such components are:

- Canopies
- Air-conditioning
- Interior lighting
- Mudguards
- Bull bars

Our policy has coverage for both voluntary and compulsory recalls.

Risk engineering

Our Crisis Management Team in Australia has a dedicated risk engineer with relevant experience in the automotive manufacturing industry, who:

- Conducts site visits and desktop reviews to have a thorough understanding of a client's business and needs
- Provides technical support to underwriters; this gives us the ability to underwrite a broad range of automotive components with sound understanding of the product exposure
- Helps clients improve their risk profile by delivering practical recommendations.

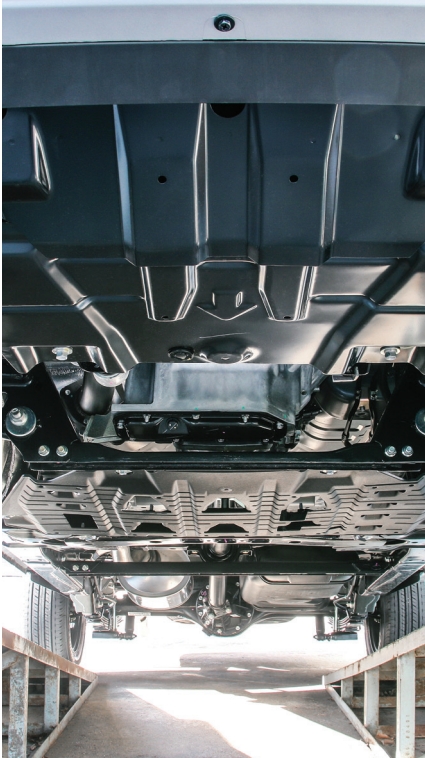

Liberty PRplus Automotive Component Recall Policy highlights



Pre-recall expense



Recall expenses



Product guarantee



Risk engineering services



Replacement and repair costs of defective products



Crisis consultant and public relations costs



Coverage flexibility - tailored made to our client's needs and budget

What makes Liberty different?

The Liberty team provides foresight and value because:

- We collaborate between our claims, risk engineering and underwriting professionals to deliver the best product in the market because we understand each client and design tailored insurance programs that will see them through a potential crisis.
- Our market-leading expertise and experience give us the ability to underwrite a broad range of risks, including 'hard to place' risks and deliver tailored covers such as third party financial loss.
- We stand by our promise to settle claims fairly, promptly and with transparency.
- The personal interaction of our collaborative team and involvement of external crisis consultants helps us minimise the impact of an incident or crisis on our clients' business and reputation.

We're part of the global Liberty Mutual Group, a Fortune 100 company that's been in business since 1912 with a Standard and Poor's 'A' rating

Global reach. Financial strength. Local authority.

Distinct, complex and constantly evolving - every business is as unique as their insurance needs. To confidently progress in the face of risk and uncertainty requires a level of security you can only achieve through working with specialists.

Liberty offers a breadth of world-class insurance and reinsurance services to brokers and insured clients. We bring value and solutions to business and government organisations across Australia - helping protect what they earn, build and own.